

1	Art. Nr. Item no. No. d'art.	Best. Nr. Ref. no. Réf.	Bezeichnung Description Désignation	B mm	H mm	b1 mm	h1 mm	L mm
	118341	FHFPT-20-2020-0-N	Halter / Basic tool holder / Porte-outil de base	20	20	20	20	125

2	Art. Nr. Item no. No. d'art.	Best. Nr. Ref. no. Réf.	Bezeichnung Description Désignation	b1 mm	HM-Sorte Carbide grade Nuance de carbure
	119287	FPT-20-8-N-FK-30	HM-Wechselplatten / Carbide inserts / Plaquettes échangeables	20	FK

	Art. Nr. Item no. No. d'art.	Best. Nr. Ref. no. Réf.	Bezeichnung Description Désignation
3	118344	FPK-20-N	Klemme / Clamp / Mors de serrage
4	107680	M6 x 20-DIN 912-SW5	Spannschraube / Fixing screw / Vis de fixation
5	111081	Ø4m6 x 16- DIN 6325	Anschlagstift / Dowel / Goujon de butée

FHFPT

FHFPT-25-2525-0-N

max. Formtiefe: t = 17 mm
 max. depth of form: t = 17 mm
 max. profondeur de profil: t = 17 mm

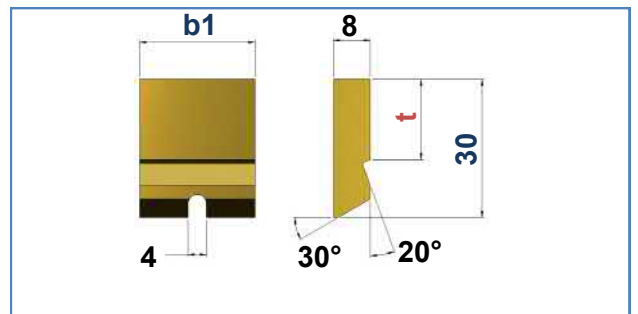
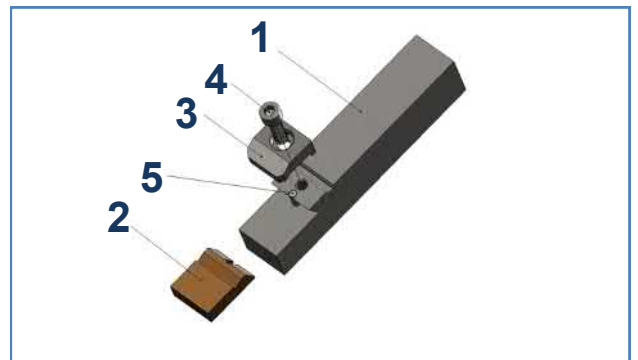
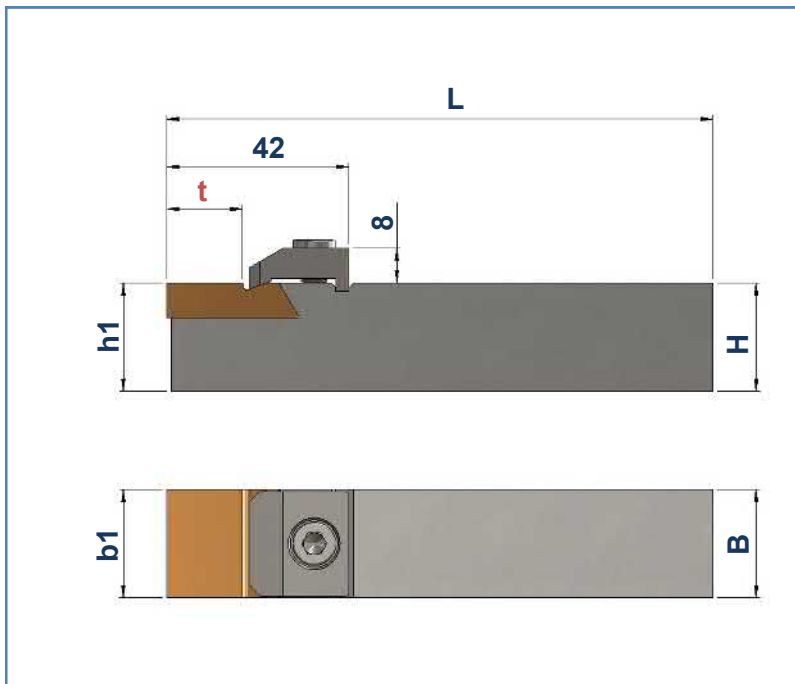

1	Art. Nr. Item no. No. d'art.	Best. Nr. Ref. no. Réf.	Bezeichnung Description Désignation	B mm	H mm	b1 mm	h1 mm	L mm
	118366	FHFPT-25-2525-0-N	Halter / Basic tool holder / Porte-outil de base	25	25	25	25	125

2	Art. Nr. Item no. No. d'art.	Best. Nr. Ref. no. Réf.	Bezeichnung Description Désignation	b1 mm	HM-Sorte Carbide grade Nuance de carbure
	119288	FPT-25-8-N-FK-30	HM-Wechselplatten / Carbide inserts / Plaquettes échangeables	25	FK

	Art. Nr. Item no. No. d'art.	Best. Nr. Ref. no. Réf.	Bezeichnung Description Désignation
3	118365	FPK-25-N	Klemme / Clamp / Mors de serrage
4	107680	M6 x 20-DIN 912-SW5	Spannschraube / Fixing screw / Vis de fixation
5	111081	Ø4m6 x 16- DIN 6325	Anschlagstift / Dowel / Goujon de butée

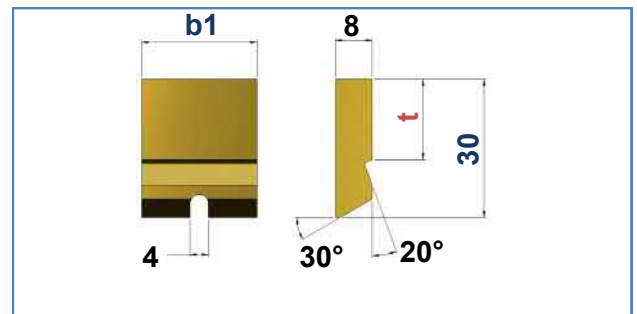
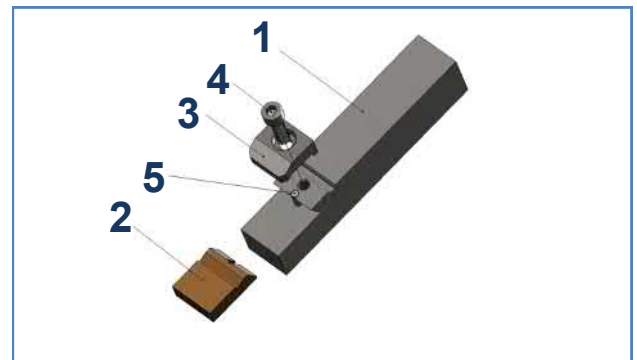
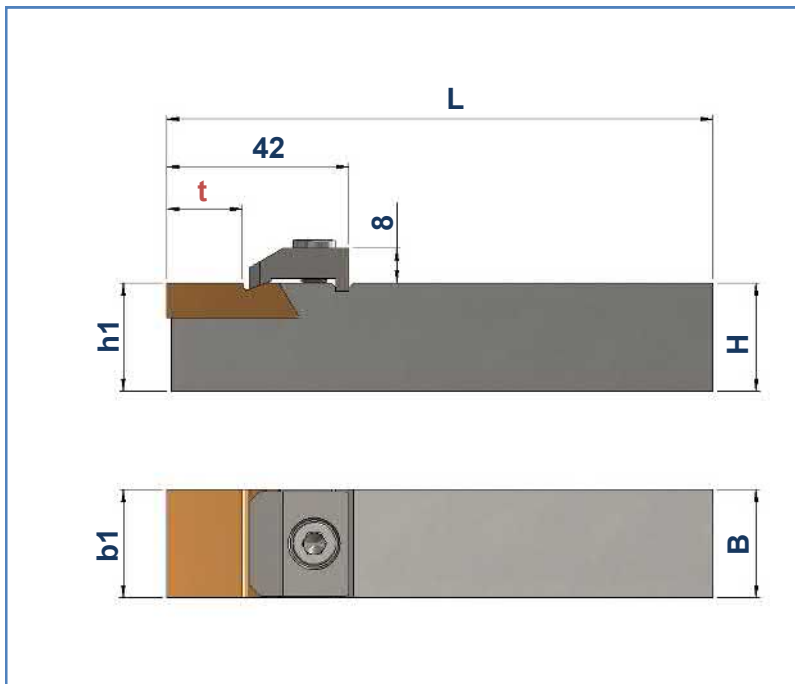

1	Art. Nr. Item no. No. d'art.	Best. Nr. Ref. no. Réf.	Bezeichnung Description Désignation	B mm	H mm	b1 mm	h1 mm	L mm
	118364	FHFPT-32-3232-0-N	Halter / Basic tool holder / Porte-outil de base	32	32	32	32	125

2	Art. Nr. Item no. No. d'art.	Best. Nr. Ref. no. Réf.	Bezeichnung Description Désignation	b1 mm	HM-Sorte Carbide grade Nuance de carbure
	119659	FPT-32-8-N-FK-30	HM-Wechselplatten / Carbide inserts / Plaquettes échangeables	32	FK

	Art. Nr. Item no. No. d'art.	Best. Nr. Ref. no. Réf.	Bezeichnung Description Désignation
3	118363	FPK-32-N	Klemme / Clamp / Mors de serrage
4	107680	M6 x 20-DIN 912-SW5	Spannschraube / Fixing screw / Vis de fixation
5	111081	Ø4 _{m6} x 16- DIN 6325	Anschlagstift / Dowel / Goujon de butée